

AVVOLGITUBO AUTOMATICO

LARGE B

AUTOMATIC HOSE REELS

TO.ME.S. DIESEL
 SINCE 1977 Made in Italy ISO 9001:2008



Avvolgitubo automatico per diesel resistente alle intemperie. Solido, compatto, con perdite di carico ridotte al minimo. Possibilità di arresto svolgimento del tubo ad ogni giro.



Ad-blue Automatic Hose Reel, weatherproof. Solid, compact, minimum pressure loss. Hose-Stop at any turn possible.

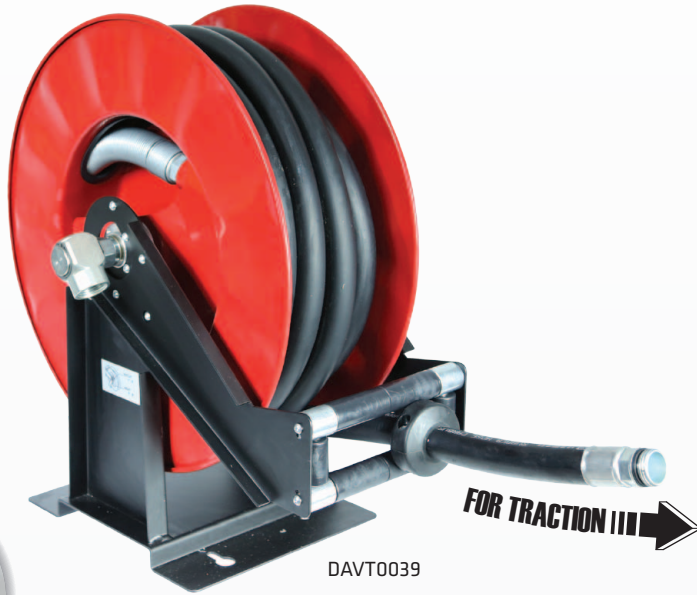

DAVT0038



STEEL

DAVT0039

- DEVICE HOSE GUIDE
- DEVICE HOSE BUMPER
- DEVICE HOSE STOP
- UP TO 15 mt
- HOSE NBR 10 bar
- AUTOMATIC RETURN HOSE



PAINTED STEEL



ANTI-CRUSHING

only with hose

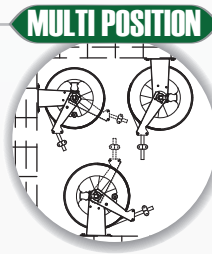

MULTI POSITION

DIMENSION (mm)

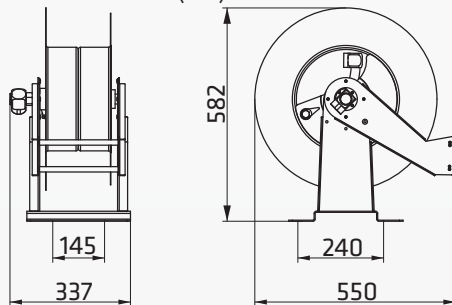

REVOLVING BRACKET

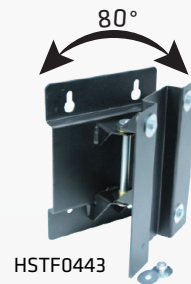

HSTF0443

name	hose including	mt ft		hose max		bar	IN	OUT	weight		packing		code
		mt	ft	mt	ft				kg	lbs	cm	inch	
LARGE B	NO			19x27	15 49,2	80	1" F BSP	1" F BSP	25	55,1	61 x 35 x 65	24 x 13,8 x 25,6	DAVT0038
				25x35	10 32,8	80	1" F BSP	1" F BSP	25	55,1	61 x 35 x 65	24 x 13,8 x 25,6	
	19x27	10 32,8			10	1" F BSP	1" M BSP	41	90,4	61 x 35 x 65	24 x 13,8 x 25,6	DAVT0149	
	19x27	15 49,2			10	1" F BSP	1" M BSP	40	88,2	61 x 35 x 65	24 x 13,8 x 25,6	DAVT0039	
	25x35	10 32,8			10	1" F BSP	1" M BSP	41	90,4	61 x 35 x 65	24 x 13,8 x 25,6	DAVT0096	