

AVVOLGITUBO AUTOMATICO

LARGE

AUTOMATIC HOSE REELS

TO.ME.S. DIESEL
 SINCE 1977 Made in Italy ISO 9001:2008



Avvolgitubo automatico per diesel resistente alla corrosione ed alle intemperie. Solido, costruito interamente in inox, con perdite di carico ridotte al minimo.
 Possibilità di arresto svolgimento del tubo ad ogni giro.



Diesel Automatic Hose Reel, weatherproof, corrosion resistant. Solid, compact, made in stainless steel, minimum pressure loss.
 Hose-Stop at any turn possible.

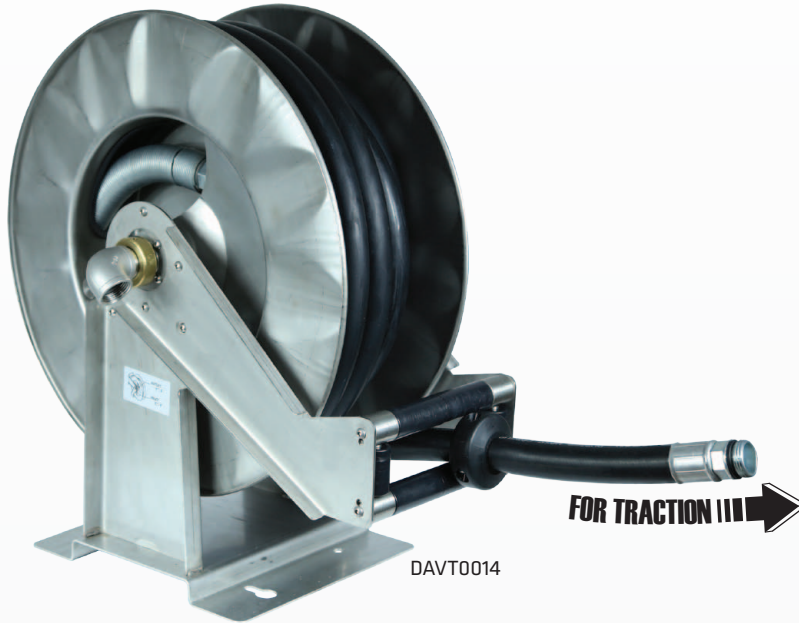

DAVT0014



DAVT0010

STAINLESS STEEL



ANTI-CRUSHING



only with hose

MULTI POSITION

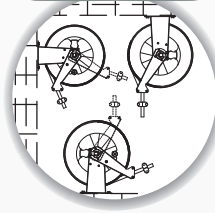

DEVICE HOSE GUIDE

DEVICE HOSE BUMPER

DEVICE HOSE STOP

UP TO 20 mt

HOSE NBR 10 bar

AUTOMATIC RETURN HOSE

DIMENSION (mm)

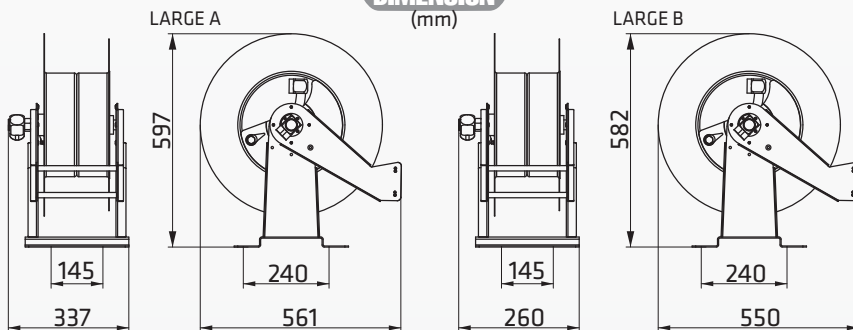

REVOLVING BRACKET

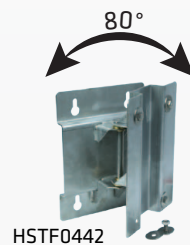

HSTF0442

name	hose including	mt ft		hose max	mt ft		bar	IN	OUT	weight		packing		code
		mt	ft		mt	ft				kg	lbs	cm	inch	
LARGE B	NO			19x27	15		80	1" F BSP	1" F BSP	33,5	73,9	61 x 39 x 61	24 x 15,4 x 24	DAVT0010
				25x35	10		80	1" F BSP	1" F BSP	33,5	73,9	61 x 39 x 61	24 x 15,4 x 24	DAVT0011
	19x27	15				10	1" F BSP	1" F BSP	48	105,8	61 x 39 x 61	24 x 15,4 x 24	DAVT0018	
LARGE A	NO			19x27	20		80	1" F BSP	1" F BSP	27,5	60,6	61 x 39 x 65	24 x 15,4 x 25,6	UAVT0012
				25x35	14		80	1" F BSP	1" F BSP	27,5	60,6	61 x 39 x 65	24 x 15,4 x 25,6	DAVT0013
	25x35	14				10	1" F BSP	1" F BSP	42	92,6	61 x 39 x 65	24 x 15,4 x 25,6	DAVT0013	
		19x27	20				10	1" F BSP	1" F BSP	43	94,8	61 x 39 x 65	24 x 15,4 x 25,6	DAVT0014